

IRRIGATION WATER METER

Model: LXXG-50-600

Use: Flow measuring instrument for measuring the total volume of water flowing through the pipeline.

Supplied conditions :

Size: DN50~DN600

Material: Cast iron shell

Temperature grade: T30, T50, T90

Pressure class: MAP16, MAP10

Pressure loss: $\Delta P63$

Installation method :

1. Horizontal installation.
2. Additional water filter is required.
3. The water inlet / outlet of the water meter needs straight pipe section U10 / D5.

Characteristics :

1. Small transmission resistance, large flow capacity, anti blocking and strong anti pollution ability.
2. Horizontal rotor, dry, magnetic coupling drive.
3. The counter adopts vacuum sealing, anti condensation and atomization, and can keep the reading clear for a long time.
4. Removable structure is adopted for easy installation and maintenance
5. The measuring mechanism has strong universality.
6. According to customers' needs, remote transmission and transmission device (double reed / hall transmission) can be provided.



Technical parameter:

DN (mm)	Flow range Q3/Q1	Metering grade	Maximum flow Q4	Common flow Q3	Boundary flow Q2	Minimum flow Q1	Minimum reading	Maximum reading
			m ³ /h				m ³	
LXXG-50	2"	R20 (R25)	25	31.25	5	1.25	0.002	999,999
LXXG-65	2 1/2"		40	50	8	2	0.002	999,999
LXXG-80	3"		63	78.75	12.6	3.15	0.002	999,999
LXXG-100	4"		100	125	20	5	0.002	999,999
LXXG-125	5"		160	200	32	8	0.002	999,999
LXXG-150	6"		250	312.5	50	12.5	0.002	999,999
LXXG-200	8"		400	500	80	20	0.002	999,999
LXXG-250	10"		630	787.5	126	31.5	0.02	9,999,999

Overall dimension and weight :

Model	DN	Length		Connection flange		
		mm		Flange outer diameter Φ D1	Number of connecting bolts ΦD2	Number of connecting bolts
LXXG-50	2"	200	253	165	125	4*M16
LXXG-65	2 1/2"	200	268	185	145	4*M16
LXXG-80	3"	225	284	200	160	8*M16
LXXG-100	4"	250	295	220	180	8*M16
LXXG-125	5"	250	310	250	210	8*M16
LXXG-150	6"	300	339	285	240	8*M20
LXXG-200	8"	350	382	340	295	8*M20 (1.0MPa) 12*M20 (1.0MPa)
LXXG-250	10"	450	438	395 405	350 355	12*M20 (1.0MPa) 12*M24 (1.0MPa)

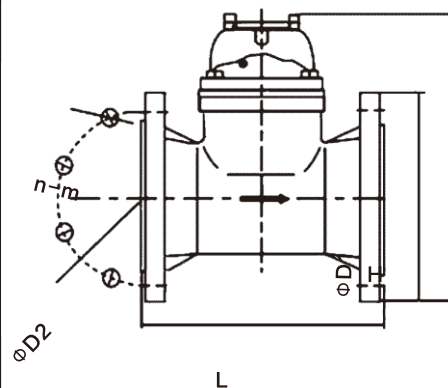

Indication error curve :

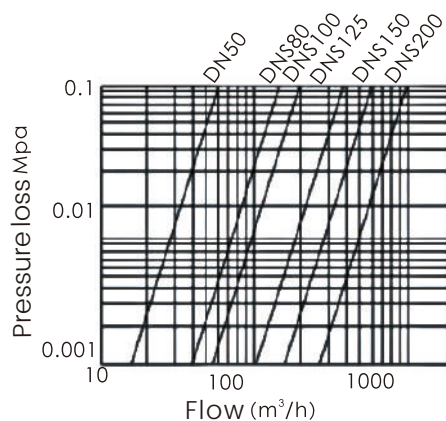

Flow error curve :

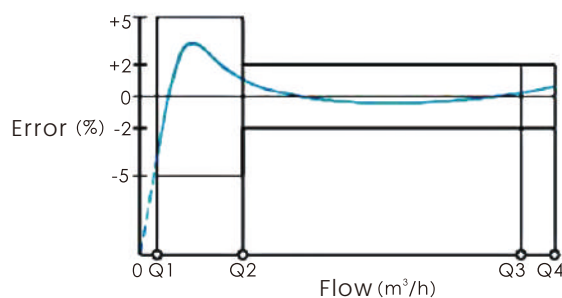

- A. The maximum allowable error of a low area ($Q1 \leq Q < Q2$) is $\pm 5\%$
- B. When the water temperature is $\leq 30^\circ\text{C}$, the maximum allowable error in the high area ($Q2 \leq Q \leq Q4$) is $\pm 2\%$
 When the water temperature is $> 30^\circ\text{C}$, the maximum allowable error in the high area ($Q2 \leq Q \leq Q4$) is $\pm 3\%$

SHENGDA
Fluid technology

Kaifeng Shengda Water Meter Co., Ltd

✉ admin@henanpanda.com

☎ mobile +86 18603780816

🌐 www.sdflovmeter.com